



B300, B600, B900
B1500, B1700



1	2
3	4

- 1 B300
- 2 B600
- 3 B900
- 4 B1500
B1700



- All bins constructed with 304 grade stainless steel
- Model B300, B600 and B900 bins have food grade polyethylene liners and non CFC foamed-in-place insulation.
- Doors lift up and slide away under icemaker to provide easy access.
- Model B900, B1500 and B1700 bins can be quickly separated into two pieces to fit through narrow doorways.
- All bins can be supplied with adaptor panels to fit a range of cube and flake icemakers.
- Storage capacities from 100kg to 690kg



B300, B600, B900, B1500, B1700

Drainage

- Drain spigot located centre back of bin.
- All bins supplied with 2.5M flexible drain hose
- Drainage point should be located at least 150mm below storagebin base.

Legs

- All bins supplied with 150mm stainless steel adjustable legs.
- Optional 300mm legs available on request

Model	Width	Depth	Height	Capacity (kg)
B300	730	600	810	100
B600	730	930	1040	220
B900	1050	930	1040	320
B1500	1800	930	1090	565
B1700	1800	1130	1090	690

All dimensions are in millimeters

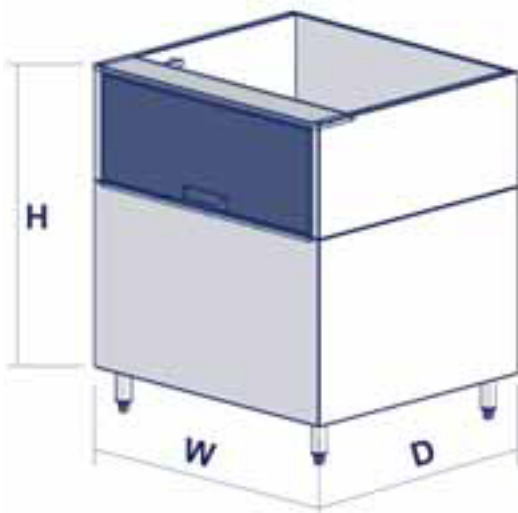

B300, B600, B900

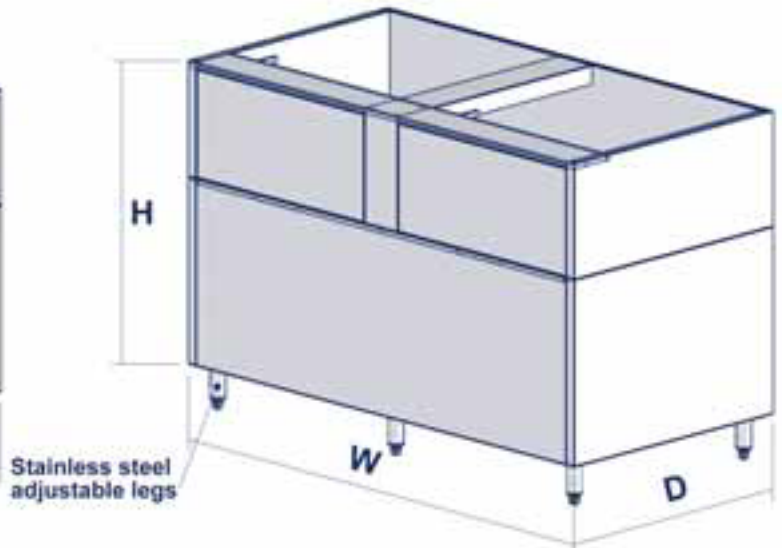

B1500, B1700

Continuing product improvement may necessitate changes of specifications without notice.

Distributed By

For more information or the name of your local sales agent call:

Stuart Manufacturing

1 Jayelem Crescent Padstow NSW 2211

Sales 1300 301 380 General Enquiries 02 9773 3711

Facsimile 02 9773 4400 Email ice@stuman.com.au

Website www.stuman.com.au