



**FINGER ICEMAKER MODELS
FI 25, FI 30, FI 40, FI 60, FI 80, & FI 120**

**INSTALLATION
AND
SERVICE MANUAL**

STUART MANUFACTURING

1 Jayelem Crescent
Padstow NSW 2211
Australia

Telephone (02) 9773 3711

Fax (02) 9773 4400

E-mail ice@stuman.com.au

TABLE OF CONTENTS

	PAGE
Specifications	1
Installation Instructions	2
Adjustments	3
Operation of Machine	4
Cleaning & Servicing	4
Trouble Shooting	5
Parts List	6
Wiring Diagram	7

SPECIFICATIONS

MODEL	FI 25	FI 30	FI 40	FI 60	FI 80	FI 120
ELECTRICAL	240V 50 hz 1.3amps	240V 50 hz 1.8amps	240V 50 hz 3.1amps	240V 50 hz 3.3amps	240V 50 hz 3.6amps	240V 50 hz 3.9amps
REFRIGERATION	R404a	R404a	R404a	R404a	R404a	R404a
WATER PRESSURE	All Models			Minimum: Maximum:	140kpa 550kpa	
OPERATING TEMPERATURES	All Models			Minimum: Maximum:	10 degrees Celsius 43 degrees Celsius	
WATER CONNECTION REQUIREMENTS	All Models			3/4" BSP male stop cock		
DRAINAGE	All Models			Floor waste or tundish below drain outlet on machine		

INSTALLATION INSTRUCTIONS

LOCATION

1. All models, allow a minimum of 100mm above or beside and behind for correct ventilation. Best performance will be achieved between 10° & 32° Celsius
2. Machine must be LEVEL
3. Incoming water temperature affects ice production. Therefore, avoid above ground plumbing and pipes exposed to direct sunlight

START-UP PROCEDURE

1. FIT ADJUSTABLE LEGS AND ENSURE MACHINE IS LEVEL
2. Connect drain hose to machine and ensure there are no kinks and it has a fall to the external drain.
3. Connect water hose to machine and tap and turn on water.
4. Connect power cord to supply and switch on power.
5. The machine will start in the harvest cycle on initial installation and fill the water trough. If the machine does not start in harvest cycle lift the bottom front panel and remove it. Turn the orange timer (see fig.1) clockwise with a screw driver until it goes into harvest and refit the front panel.

ADJUSTMENTS

There are only two adjustments which can be made to the machine, ice size and bin capacity. The machine should be allowed to complete two (2) cycles before making any adjustments.

ICE SIZE

DO NOT ADJUST DURING HARVEST CYCLE

Ice size has been factory set but can be adjusted between approximately 10g and 32g

To adjust the ice size lift the bottom front panel and remove it.

This gives access to the ice adjustment screw (see fig. 1)

Using a screwdriver, turn clockwise to increase and anticlockwise to decrease ice size. It is best to make only small adjustments until desired size is achieved.

Replace front panel after adjustment

BIN CAPACITY

The machine will automatically stop when the temperature in the storage bin reaches the preset level, therefore the height (amount) of ice in the bin will vary from winter to summer. To maintain the optimum level the bin thermostat (see fig.1) needs to be adjusted.

To adjust the ice level lift the bottom front panel and remove it.

This gives access to the bin thermostat adjustment screw (see fig. 1)

Using a screwdriver, turn clockwise for winter and anticlockwise for summer. It is best to make only small adjustments until desired level is achieved.

Replace front panel after adjustment

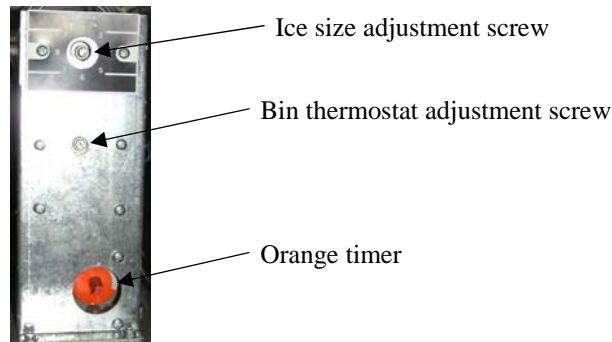

Fig 1

OPERATION OF MACHINE

NOTE! Compressor does not start for approx. 1 min. On initial start-up

On initial start-up the machine will run through a harvest cycle (approx. 1 min.) during which time the heat exchanger and water trough will fill. Excess water will flow down the drain. At the end of this cycle the timer will stop.

The compressor and water pump will start and the freezing cycle commences.

When the evaporator thermostat (ice size adjustment) senses that the evaporator has reached the correct temperature the timer will restart and run for 5 mins. At the end of the freezing cycle **the compressor and pump will stop** and the water solenoid will open. The warm water in the heat exchanger will flow over the evaporator and harvest the ice.

The cooled water (approx. 8° Celsius) will refill the water trough.

These machines do use hot gas for the harvest cycle

CLEANING

CONDENSER CLEANING

A dirty condenser causes loss of production and could damage the unit, therefore it should be cleaned at least every three months (more frequently in dusty environments)

Disconnect the power and remove the bottom front panel to access the condenser.

Using a stiff brush clean the face of the condenser, then use a vacuum cleaner to draw dust out of the condenser.

Replace front panel after

CAUTION: Condenser fins have sharp edges and can cause lacerations

INTERNAL CLEANING

After cleaning the condenser remove ice from storage bin.

Remove the top panel, then remove the water curtain assembly by lifting it straight up. This provides easy access to the water trough. Remove the spray jets and clean with a toothbrush or similar. When replacing spray jets ensure the slot is aligned front to back. Using a clean cloth wipe the trough and storage bin to remove dirt.

Use an approved sanitiser or a mixture of vinegar or citric acid and water.

Refit the water curtain assembly and top panel

TROUBLESHOOTING

The icemaker doesn't work

Check if the storage bin is full
Check that power is on
Check circuit breaker at main fuse board

The icemaker works but it doesn't produce ice or the ice is melting in the storage bin

Check that the ice slide behind the water curtain is properly fitted. It should slope from back to front to allow the ice to slide into the bin.
Check that the storage bin is draining correctly.

The ice is not fully formed and/or is cloudy

Check spray jets for blockages
Check filter in water trough and water inlet valve for blockages
Check water pump and inlet valve are working
Fit filter to water supply to remove minerals

The icemaker works but has low production

Check icemaker has adequate ventilation and is not situated in hot area
Check water supply is not in direct sunlight or hot area
Check condenser may need cleaning
If none of these apply call service technician

The icemaker produces very thick ice and wont harvest

Call service technician, evaporator thermostat may be faulty

WATER CIRCUIT DIAGRAM

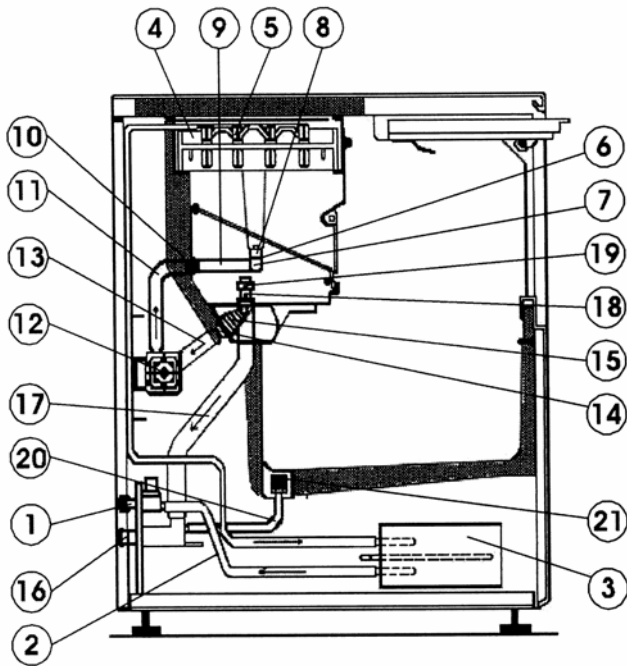

1. Water inlet valve
2. Water inlet pipe
3. Heat exchanger
4. Evaporator gasket
5. Evaporator
6. Water distributor
7. Plug for water distributor
8. Spray jets
9. Distributor inlet hose
10. Water pump outlet pipe
11. Water pump outlet hose
12. Water pump
13. Water pump inlet hose
14. Water pump inlet pipe
15. Pump filter
16. Water drain
17. Overflow drain hose
18. Overflow
19. Overflow cup
20. Bin drain hose
21. Bin drain connecting pipe

REFRIGERATION CIRCUIT DIAGRAM

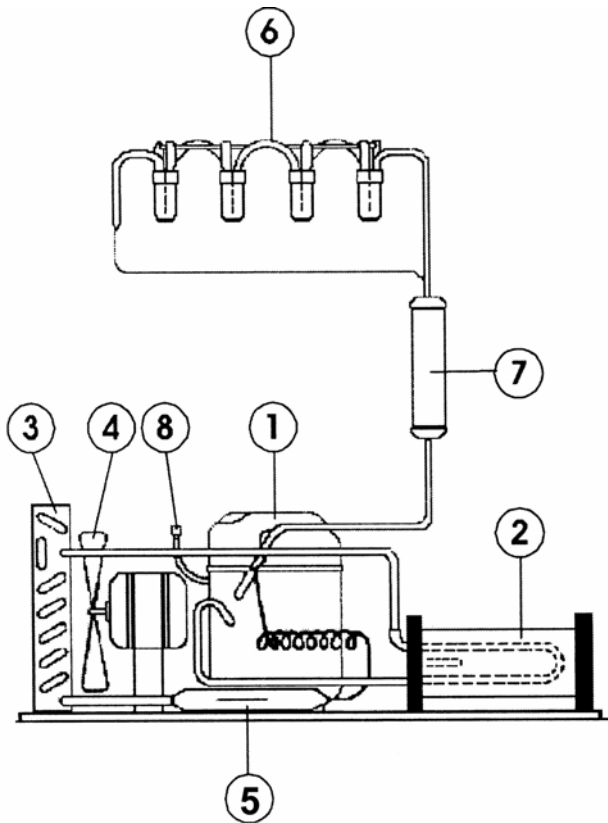

1. Compressor
2. Heat exchanger
3. Condenser
4. Fan/motor
5. Filter drier
6. Evaporator
7. Accumulator
8. Access valve

WIRING DIAGRAM

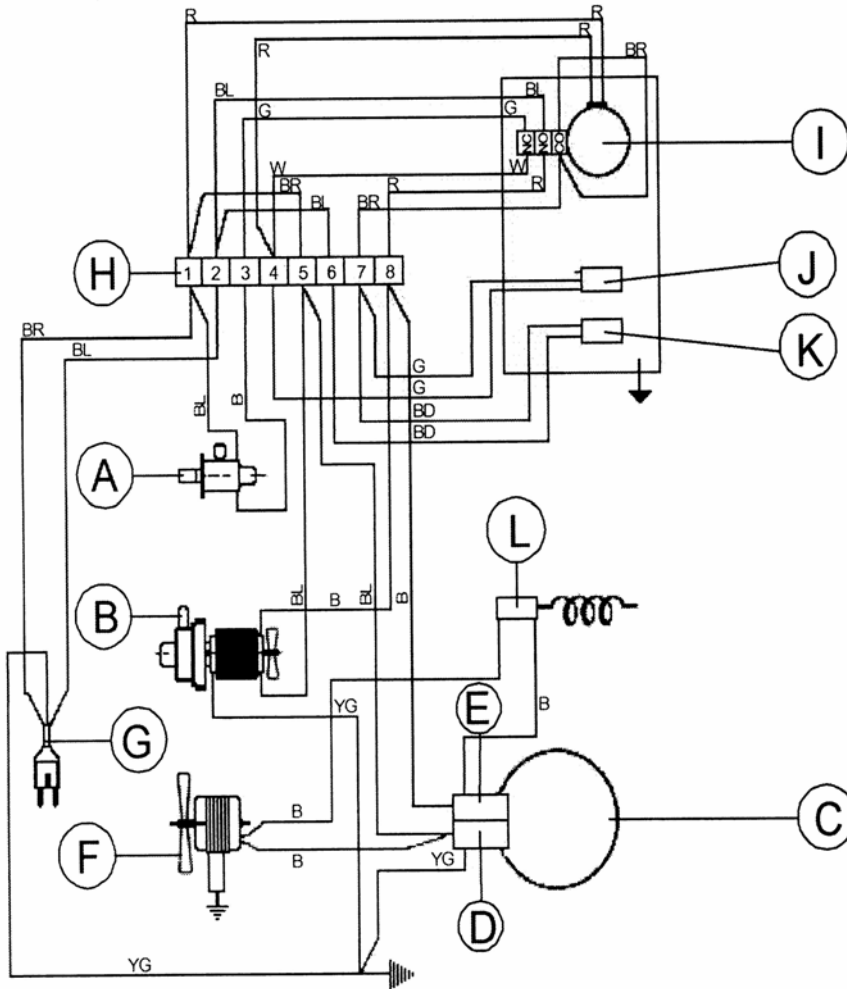

- A. Water inlet valve
- B. Water pump
- C. Compressor
- D. Compressor start relay
- E. Thermal overload
- F. Fan motor
- G. 10 amp, 3 pin plug
- H. Terminal block
- I. Timer
- J. Bin thermostat
- K. Evaporator thermostat
- L. Fan control

- BL Blue
- B Black
- G Green
- R Red
- W White
- BR Brown
- YG Yellow/Green